

# Let's make sailing safer

At Mac N Hom Marine Equipments (P) Ltd., we are focused on range of products that meet the ever increasing demands of Marine based customers in terms of sophistication and diversification. We have brought to market innovative products, one after another to provide only the highest quality goods and services for your requirements and offer customised solutions and challenging applications quickly and cost effectively.

**MAC·N·HOM**  
**MARINE EQUIPMENTS (P) LTD.**  
 Let's make sailing safer



## HYDRAULIC STEERING SYSTEMS

**Model : BHIMA**  
 IRS Type Approved



**Model Type : Balanced Actuator ( IRS Type Approved)**  
 Ram Dia : 25 mm    Stroke : 260 mm  
 Torque : 93.53 Kg.m for a Tiller Arm having Radius 220 mm

Ferry boats of 75-200 Pax.    Concrete Transportation Barges  
 Large House Boats    Solar Ferries    Propulsion Barges

**Ferry Boats-52 Nos**  
 State Water Transport Dept. Kerala



**ADITYA: India's first Solar-Powered Ferry**



**Concrete Barge**  
 Unotech Marine Engineering Services, Ernakulam



**Catamaran Passanger Boats-23 Nos**  
 Kochi Water Metro 100pax.



**Balanced Hydraulic actuator- Model: BHIMA**  
 With Swivel Rod Eye to Connect with Tiller Arm

- ◆ More than 150 installations in Passanger Ferries of 100/200 pax, medium Barges, Choonda Boats.
- ◆ Torque Rating of 750Nm (with 180mm Tiller Arm)
- ◆ Heavy Duty Ram size: 25mm
- ◆ Second Thread on other end of Piston Rod for Emergencies.
- ◆ 12 Months Warranty against Manufact. Defects
- ◆ On-Line Installation and Service Support
- ◆ Spares including Seal kits readily available

### Package Included

- Manual-Hydraulic Package:**
- ❖ Steering Wheel - Wooden/SS
  - ❖ Helm Pump, Steering Column & Self priming unit
  - ❖ Marine Painted Ferruled Seamless steel Tubes & Hoses
- Hydraulic Actuator-BHIMA**
- Electro-Hydraulic Package:**
- ❖ Joystick Control Panel
  - ❖ Hydraulic Power pack & Sensors
  - ❖ Emergency Manual-Hydraulic Steering
  - ❖ Marine coated Ferrules Tubes & Hoses
  - ❖ Hydraulic Actuator - **BHIMA**

- 1 Joystick Operated Control Panel with audio visual alarms
- 2 Electro Hydraulic Power Pack with Sensors for Electro Hydraulic Package
- 3 Marine Paint Coated, Ferruled Nut ends Seamless Steel Tubes for Smooth Oil Flow
- 4 Emergency Manual Hydraulic version with Helm Pump, Steering Wheel & Self Priming Unit



**SPECIFICATIONS**

- Actuator Ram Diameter : 25 mm.
- Actuator Stroke : 260 mm.
- Force @ 45 Kg. / cm<sup>2</sup> Hydraulic Pressure : 661.95 Kgf.
- Torque with 180 mm. Tiller Arm for ±45° turn from Midship (Actuator Pin to Rudder Shaft Centre distance : 180 mm.) : 76.53 Kgm.
- Torque with 220 mm Tiller Arm for ±35° turn from Midship (Actuator Pin to Rudder Shaft Centre distance : 220 mm.) : 93.53 Kgm.

**MOUNTING ARRANGEMENT OF HYD. ACTUATOR BHIMA - IRS**

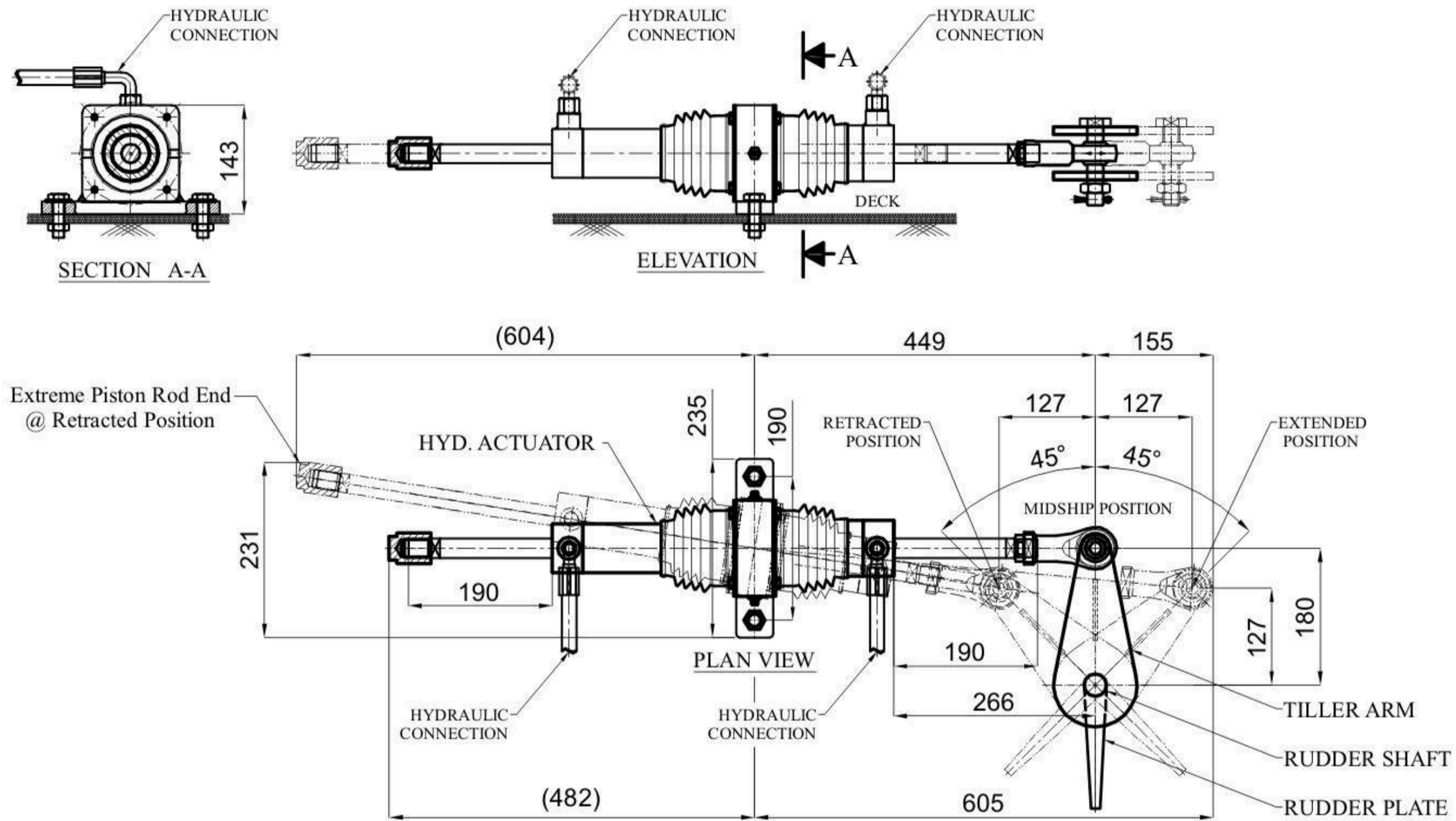

**DATA FOR STEERING SELECTION**

VESSEL DETAILS		
Length of the Vessel		Meters
Breadth of Vessel		Meters
Draft of the Vessel		Meters
Hull form ( Mono / Catamaran )		
No of Engines		Nos.
Power of each Engine		HP
Speed of Vessel		Knots
RUDDER DETAILS ( See Rudder Dwg. )		
Breadth of Rudder A		Meters
Breadth of Semi-balanced Area B		Meters
Height of Rudder H		Meters
Number of Rudders		Nos.
Vessel Regn. Class - No Class / IRS / RINA / DNV / BV		

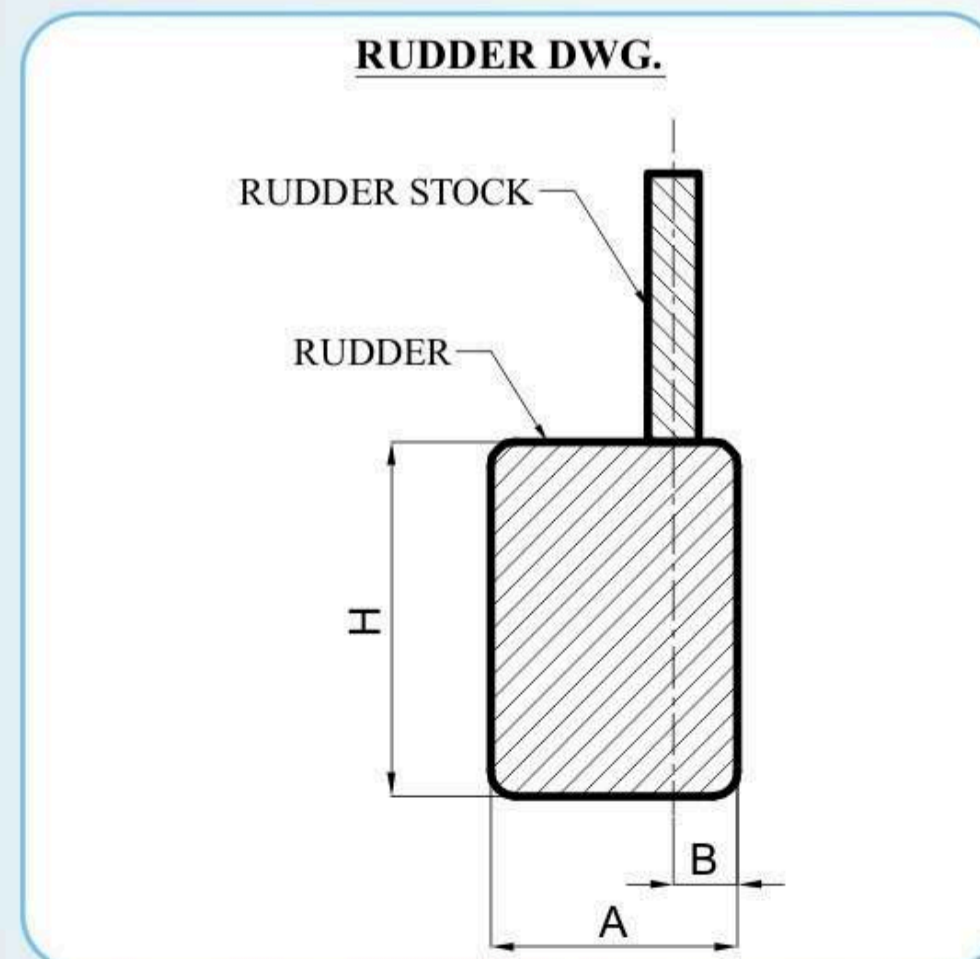

NOTES : 1. Please fill in this data sheet with your Vessel data, and email to [info@macnhomsystems.com](mailto:info@macnhomsystems.com) OR Whatsapp to +91 90729 00576.  
 2. All dimensions are in mm.  
 3. Dimensions are reference purpose only; kindly confirm with our Technical Department.